

DREH- UND SPANNFUTTER

Schweißspannfutter - 3- und 4-Backen Spannfüter zentrisch spannend

D-WPS

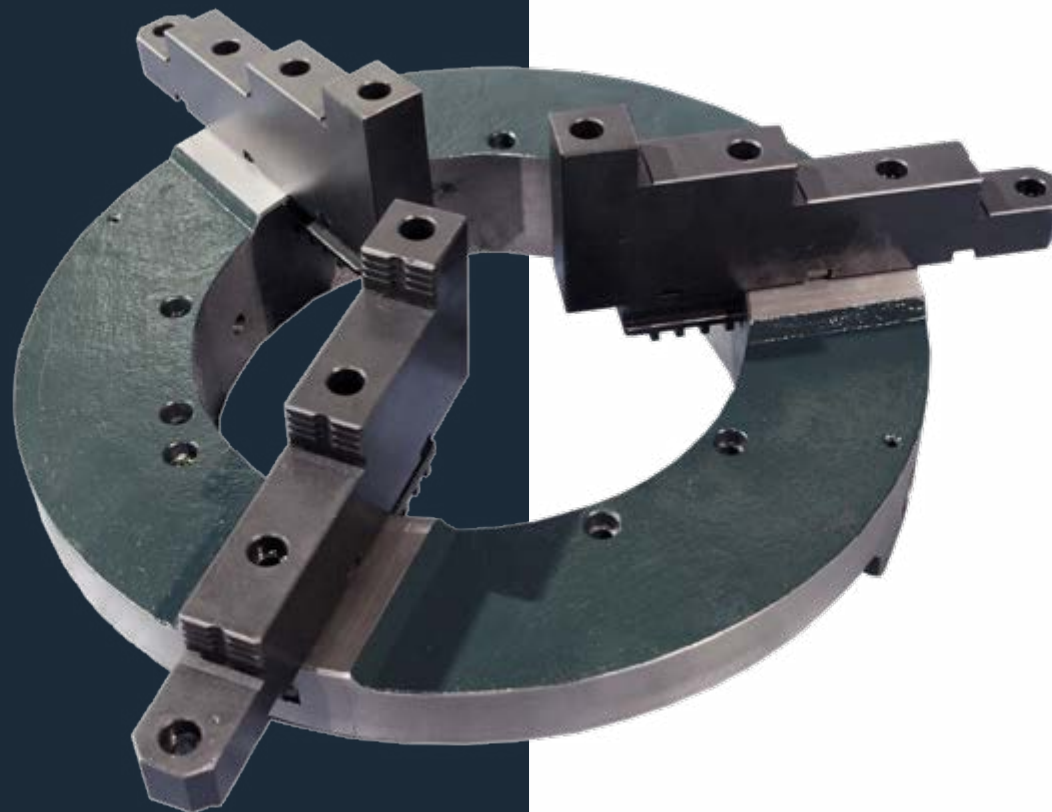

D-WPS3-600



DREH- UND SPANNFUTTER

Schweißspannfutter - 3- und 4-Backen Spannfutter zentrisch spannend

D-WPS

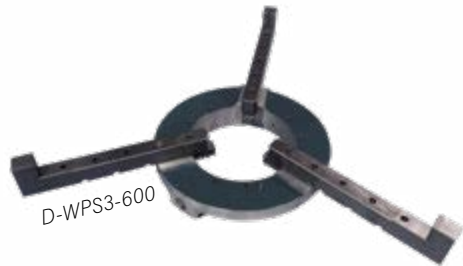

D-WPS3-600



D-WPS3-600

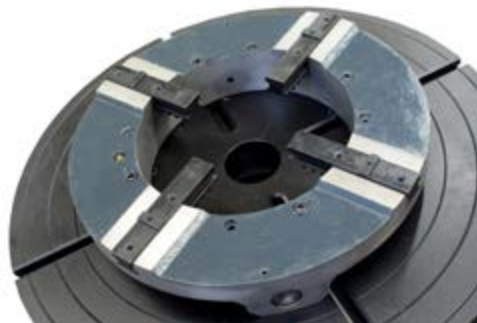

D-WPS4-600



D-WPS4-600

MERKMALE

- Zum Spannen runder und rechteckiger Bauteile
- Spannbereich $\text{Ø}80 - \text{Ø}1500$
- Zentrisch spannend
- Große Durchgangsbohrung
- Geringes Eigengewicht d.h. auch geeignet für kleinere Schweißdrehtische
- Hohe Spannkraft: 50 KN
- Vier (4) Sets Backen inklusive



DREH- UND SPANNFUTTER

Schweißspannfutter - 3- und 4-Backen Spannfüter zentrisch spannend

D-WPS

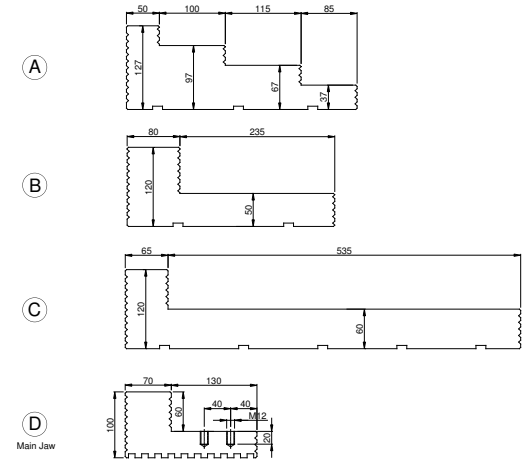
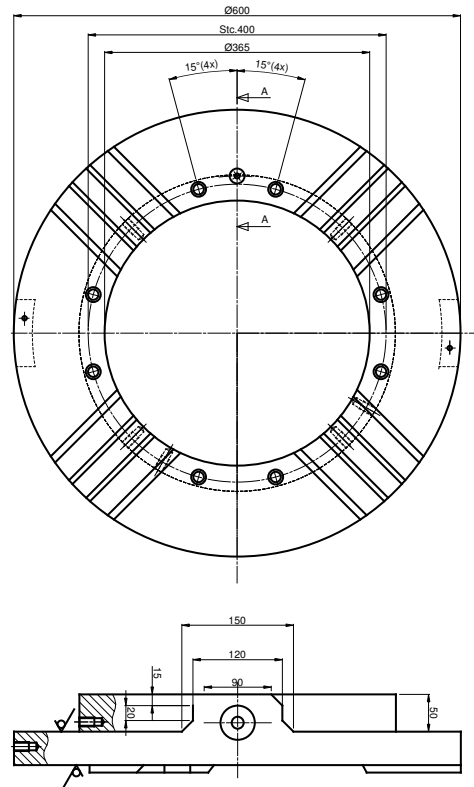
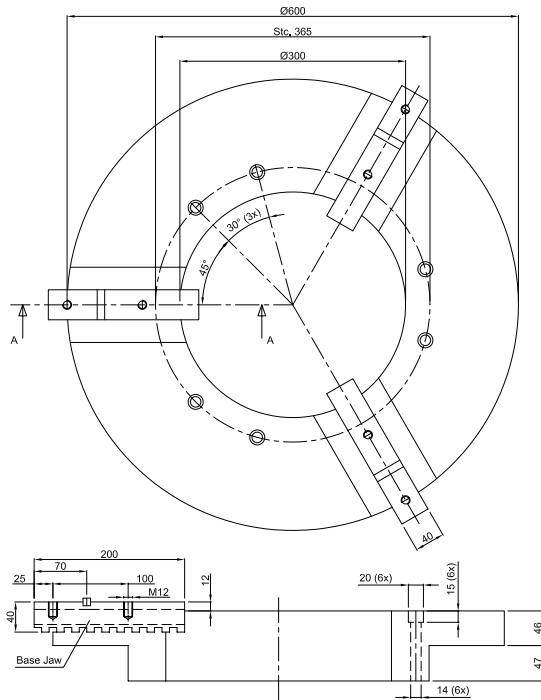

Backenmaße D-WPS3-600 / D-WPS4-600